

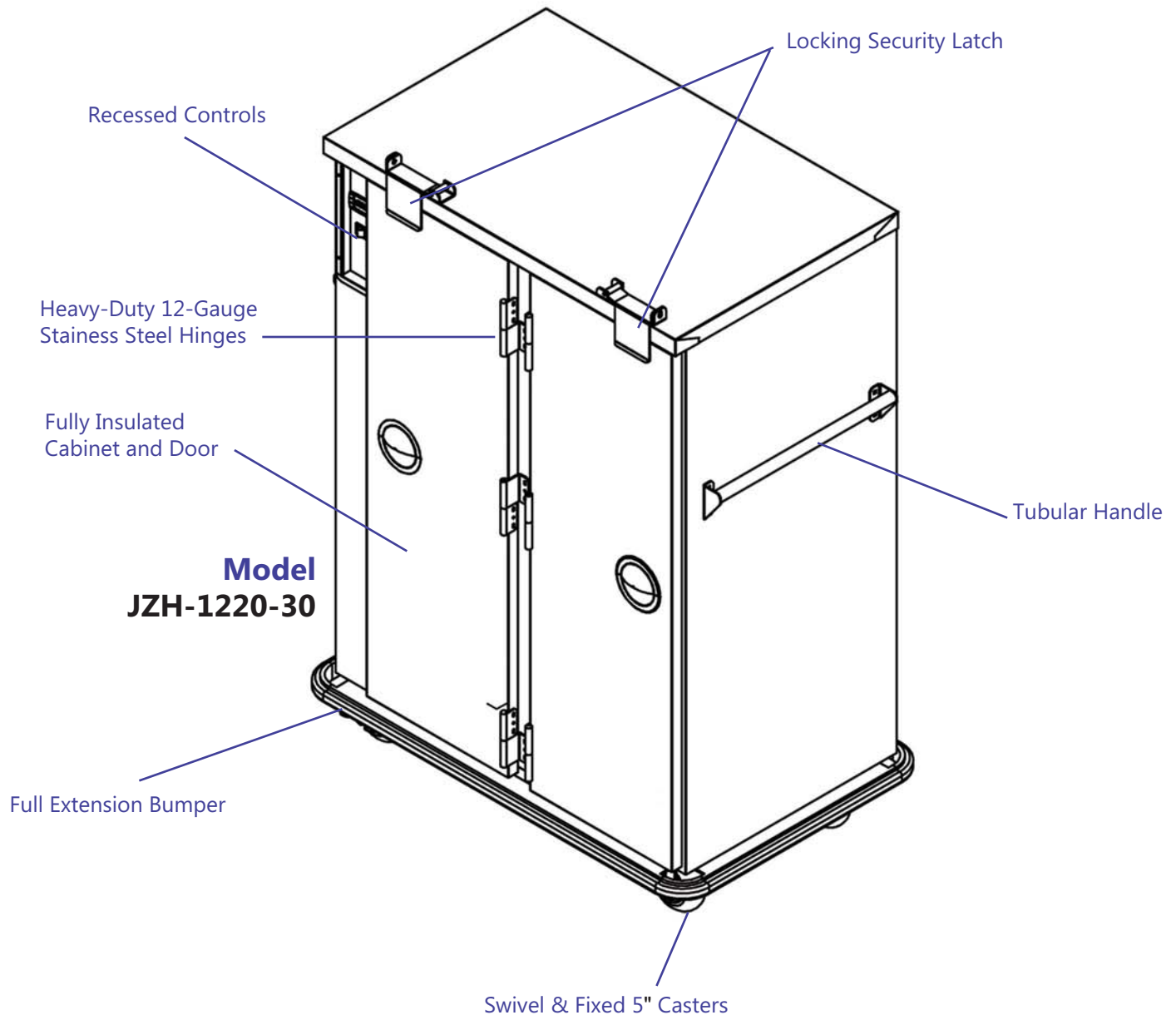

# Jones Zylon

## Product Specification JZH-1220-30



# JZH-1220-30

Fixed Spacings @ 2.625"

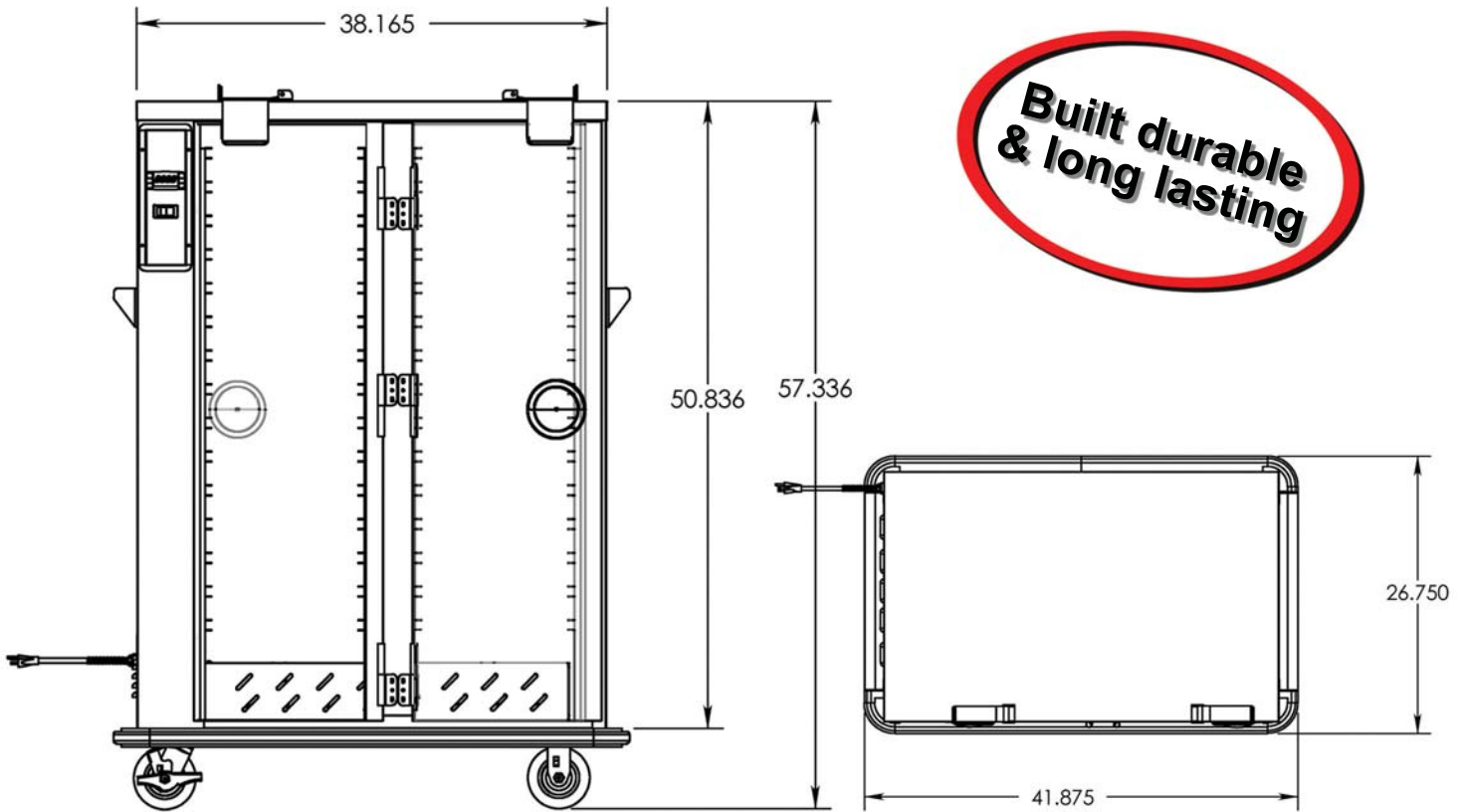

<b>Capacity:</b> 12" x 20" Pans 30 Pans 2.5" Deep 14 Pans 4" Deep 10 Pans 6" Deep	<b>Exterior Dimensions:</b> Height: 57.34 Depth: 26.75" Width: 41.88"	<b>Interior Dimensions:</b> Height: 48.00" Depth: 21.83" Width: 31.44" 14.16" Each Compartment	<b>Electrical Data:</b> Volts: 120 Amps: 13.3 NEMA Plug: 5-15P
			<b>Crated Weight:</b> 315 LBS

This cabinet accommodates shallow and deep 12" x 20" pans.

This cabinet is built tough using stainless steel throughout. The stainless steel base frame will ensure that this cabinet will withstand the most demanding use.

Cabinet is **fully insulated**, including the bottom floor base of the cabinet - not just the door.

---

Made in USA

All specifications subject to change without notice.